

# Grease separators for free-standing installation

## EasyClean Mix (D+S)

NS 2 - 10



Illustration shows Art. # 93 004.31/DS

**Certification:** Z-54.1-474

**Delivery:**  
System completely assembled.

**Accessories:**  
Sampling chamber, lifting stations

**Grease separator  
EasyClean Mix (D+S) NS ...**

according to Euro Norm EN 1825, manufactured from virgin, non-recycled polyethylene, pumping capacity 3.0 kW

5 m cable length

For free standing installation in frost protected areas, with integrated sludge trap, sloped interior base improves cleaning and reduces disposal time, inlet flow calming system and outlet flow regulation device, inlet and outlet interchangeable, slanted twin access covers with quick release odour tight snap closures, inspection window with interior cleaning arm, D+S version with simultaneous mixing and cleaning of separator interior - requires disposal truck with vacuum system for separator disposal, disposal is completely odour free, maintenance free macerating motor (stainless steel blades) includes closure valve for easy motor removal, motor floor mount included with installation hardware and anti-vibration matt, top mounted water jet(s) for grease layer breakup and water spray nozzles for interior wall cleaning during disposal, 1 inch interior thread refill inlet with air gap, 1 inch manual hand valve for water refill, with hand held operation controller, 75 mm OD PN 10 pressure disposal pipe, with integrated fork lift grips at base of separator, low weight - compact design, 100 % corrosion free polyethylene body construction (20 year warranty).

NS	Weight	Article #	
<b>without SonicControl</b>			
		without inspection window	with inspection window
NS 2	145 kg	<b>93 002.01/DS</b>	<b>93 002.31/DS</b>
NS 3	150 kg	<b>93 003.01/DS</b>	<b>93 003.31/DS</b>
NS 4	163 kg	<b>93 004.01/DS</b>	<b>93 004.31/DS</b>
NS 7	211 kg	<b>93 007.01/DS</b>	<b>93 007.31/DS</b>
NS 10	257 kg	<b>93 010.01/DS</b>	<b>93 010.31/DS</b>
<b>with SonicControl</b>			
		without inspection window	with inspection window
NS 2	145 kg	<b>93 002.02/DS</b>	<b>93 002.32/DS</b>
NS 3	150 kg	<b>93 003.02/DS</b>	<b>93 003.32/DS</b>
NS 4	163 kg	<b>93 004.02/DS</b>	<b>93 004.32/DS</b>
NS 7	211 kg	<b>93 007.02/DS</b>	<b>93 007.32/DS</b>
NS 10	257 kg	<b>93 010.02/DS</b>	<b>93 010.32/DS</b>

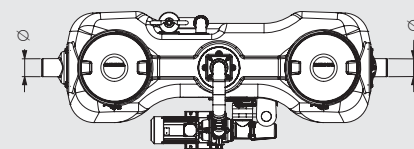
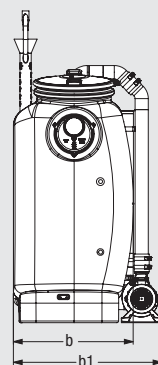
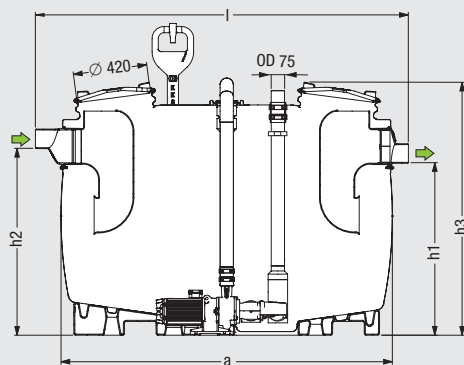

∅ = Outer diameter  
b1 = Set-up dimensions

Technical note see page 283

Nominal size	∅	a	Installation dimensions				b1	h1	h2	h3	Sludge	Grease	Total (including water)
			l	x	b								
NS 2	110	1500	1735		680	860	985	1055	1435	200 l	100 l	600 l	
NS 3	110	1500	1735		680	860	985	1055	1435	300 l	120 l	600 l	
NS 4	110	1880	2115		680	860	985	1055	1435	400 l	160 l	800 l	
NS 7	160	1910	2145		940	1130	1185	1255	1655	700 l	280 l	1350 l	
NS 10	160	2590	2820		940	1130	1185	1255	1655	1000 l	400 l	1900 l	

## Grease separators for free-standing installation

### Installation example *EasyClean Mix (D+S)*



- |                                 |                    |
|---------------------------------|--------------------|
| ① Grease separator              | ⑤ Sampling chamber |
| ② Shredder-Mix-System           | ⑥ Lifting station  |
| ③ Disposal line                 |                    |
| ④ Connection for disposal truck |                    |

*EasyClean Mix (D+S)* grease separators are designed according to EN 1825-1 and are equipped with a manually controlled pump for mixing and cleaning of the separator's contents and inner walls. These separators distinguish themselves through their ease of installation and nearly maintenance-free characteristics.

The advantage of the *EasyClean Mix (D+S)* separators is that disposal can take place through permanently installed disposal lines while the twin covers of the separator remain closed. With this advantage, the disposal truck hooks up to a connection on an exterior wall of the building and, using its own pump, suctions out the entire contents of the separator without any unpleasant odours escaping.

The Shredder-Mix-System macerates and liquifies its contents and also cleans its interior walls all simultaneously. This prepared wastewater is then suctioned into the waiting disposal vehicle. According to DIN V 4040-2, the complete contents of the separator should be emptied, the unit cleaned and refilled with clean cold water every fourteen days or at a minimum of once every month.

### Professional advantages

- **Direct disposal with Shredder-Mix-System for homogenisation of the tank contents**
- **Clean and odour-free disposal and cleaning**
- **Simple control**
- **Low-maintenance operation**
- **Complete System Solution**  
In addition to individual grease separators, KESSEL also offers complete separator packages consisting of grease separator, properly matched lifting station and advantageous accessories. All from one source - KESSEL.
- **Individual Solutions**  
KESSEL offers a fully staffed Individual Solutions Department with experience in designing and manufacturing drainage products exactly meeting your specifications. For additional information please contact us directly to discuss your requirement. Contact information is found on page 5.
- **Grease separator calculation**

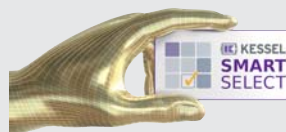

**SmartSelect** simply makes planning easier – calculation tool for separators at [smartselect.kessel.com](http://smartselect.kessel.com)



Scan this QR code to directly view the corresponding product video.



### Installation hints

Important is that a sampling chamber is installed after the outlet of the separator. The separator is installed completely level on a flat firm surface in a frost-free area. The height of the room in which the separator is installed should allow easy removal and access of the two lids. In the case that the outlet of the separator is located below the local defined backwater level, a lifting station is to be installed according to EN 12056. In situations where the interruption of separator service is not allowable, a lifting station with double pumps is to be installed.

### Notice

*EasyClean Mix (D+S)* grease separator is ideal for installations where the presence of strong odours during disposal of the separator's contents can not be permitted. The "Shredder-Mix-System" liquifies, macerates and cleans the separator's contents all in one step.